



600 Wabash Ave.
Terre Haute, IN 47807
812.234.5190
812.234.7346 Fax

PROJECT: Indiana State University
Dreiser Theater Stage Renovation

PROJECT NUMBER: 12013

DATE: August 29, 2012

PREPARED BY: Cari Rohrmayer

ADDENDUM

Number: ONE

This Addendum is issued in accordance with the provisions of "The General Conditions of the Contract for Construction," Article 1, "Contract Documents" and becomes a part of the Contract Documents as provided therein. This Addendum includes:

- A. Addendum Pages: ADD1-1 through ADD1-1 as prepared by MMS-A/E, Inc.
- B. Attachments: Supplemental Drawings #1 and #2
Question and Answers
Pre-Bid Meeting Report
Revised Bid Form
Revised Spec Section 012360

PART 1 - BIDDING & CONTRACT REQUIREMENTS

- 1.01 Bid Form Revised to include an Unforeseen Condition Allowance

PART 2 - SPECIFICATIONS

- 2.01 012360 Revised to include an Unforeseen Condition Allowance

PART 3 - DRAWINGS

- 3.01 SD1 – Access Panel Clarification
- 3.02 SD2- Unit Price One Clarification

ADD 1-1

Please acknowledge receipt of Addendum No. 1 on bid form.

QUESTION AND ANSWERS:

- Q1. What are the load requirements for the steel framing of the trap doors?
- A1. 100 PSF
- Q2. What materials are to be used?
- A2. C 8x13.5
- Q3. Is the unit price for double 2 x 12 x 3 beam /lnl. Ft. (as in specs) or for remove and replace of 3" tongue and groove and underlayment? (as noted on 1A200)
- A3. See SD2 to clarify Unit Price #1. T&G removal and replacement to be included in base bid.
- Q4. What type of tongue and groove flooring at the proscenium?
- A4. 3", oak planks
- Q5. On 2/A200 you show base. Is this just vinyl base?
- A5. No, 4" wood base to be painted
- Q6. Will the existing trap doors need a leveler before new MDF is applied?
- A6. Yes.



Pre-Bid Conference Agenda / Information

DATE: August 24, 2012
TIME: 10:00 AM
LOCATION: Dreiser Theater

Introduce Project..... **Dreiser Theater Stage Renovation**

Architect/Engineer: **MMS-A/E, Inc.**
600 Wabash Ave
Terre Haute, IN 47807

Main Contact: Cari Rohrmayer Phone (812) 234-5190 Fax: (812) 234-7346
E-mail crohrmayer@mmsae.com

Other A/E Contacts:
All questions regarding this Project shall be submitted through the A/E Main Contact

Introduce Facilities Management Team
Project Coordinator: Bryan Duncan (812)-237-8195 e-mail bryan.duncan@indstate.edu
Owner's Project Manager: Steve Culp (812)-237-8183 e-mail steven.culp@indstate.edu
Mechanical Representative: Mark Pupilli (812)-237-8185 e-mail mark.pupilli@indstate.edu
Electrical Representative: Pat Teeters (812)-230-6141(cell) e-mail patrick.teeters@indstate.edu

Construction Documents Available at:
Office of the Purchasing Department
Facilities Management and Purchasing Building
951 Sycamore Street
Terre Haute, Indiana 47809

Forms for Bidding:
Published Bid Form (Section 002000 of Project Manual)
Bid Bond or Check
Non-Collusion Affidavit (on Bid Form, submission of Bid confirms compliance)
Form 96A (or latest audited financial statement)
Addendums indicated (on Bid Form)
Duration of construction (on Bid Form)
Debarment Form (Section 001020 of Project Manual)
Diversity Participation List (Section 001040 of Project Manual)

Submit Bids and other information to:
Office of the Purchasing Department
Facilities Management and Purchasing Building
951 Sycamore Street
Terre Haute, Indiana 47809

Bid Date: August 31, 2012 Time: 10:00 AM

Common Construction Wage Project: Yes

Supplier/Subcontractor list: **Appendix A, submit with Bid**
Unit Prices: **Appendix B, submit with Bid**
Type of Bid: **Single Prime**
Award Date: **Within seven (7) days or less**
Alternates: **None**
Allowances: **Section 012360:**
\$40,000.00 shall be included in the Base Bid for Fly Rigging.
Start Date of Construction: **September 7, 2012**
Substantial Completion: **December 10, 2012**
Project Closeout: **Two weeks thereafter**
Tax Exempt (non profit) **Indiana State University is a Tax Exempt Institution and Indiana Sales Tax for products permanently incorporated in work shall not be included as part of the Bid or on any Application for Payment.**
Hours of Construction: **Normal 7:00am-4:00pm**
Permits and fees: **Include with Bid**
Asbestos or other hazardous materials: **None Anticipated; if suspicious material is encountered, stop work immediately and contact the Owner for clearance or removal.**
General Project Information and Requirements:
Site protection: **See Specifications**
Material storage: **On-site**
Parking: **See Section 003000 1.06 for requirements**
Communication: **Job Superintendent shall have a cellular phone.**
Fire Protection: **See Section 003000 1.08 C for requirements**
Salvage: **The Owner has the right of first salvage. The Owner will supply a list of any items, not slated for reuse, which the Owner wishes to salvage. All items to be salvaged will be delivered to a location on the ISU campus as directed by the Owner.**
Coordination With Owner: **A minimum of 48 Hours prior notification of any closings, areas to be blocked off or utility shutdowns.**
Smoking Policy: **See Section 003000 1.05 for Rules**

Consultant Comments: Ann Warren is on site from 8am-5pm most days. Her extension is : 3284

Contractor questions:

Will tongue and groove flooring need sealed before MDF over layment- Yes, *clear coat*.

Site Tour –ISU: **Coordinate with MMS if needed.**

Additional Site Tour – Date: **None Scheduled**

e.c. Electronic Project Folder

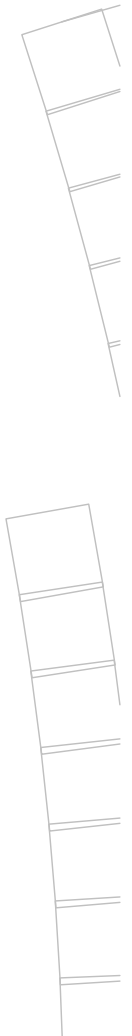

REMOVABLE
SCREWS &
FINISH
WASHERS

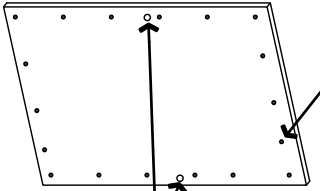

REMOVABLE
ACCESS PANEL

CAM LOCKS

PANEL
TO BE REMOVABLE
W/ PAINTABLE HARDWARE

3'-8 3/16"

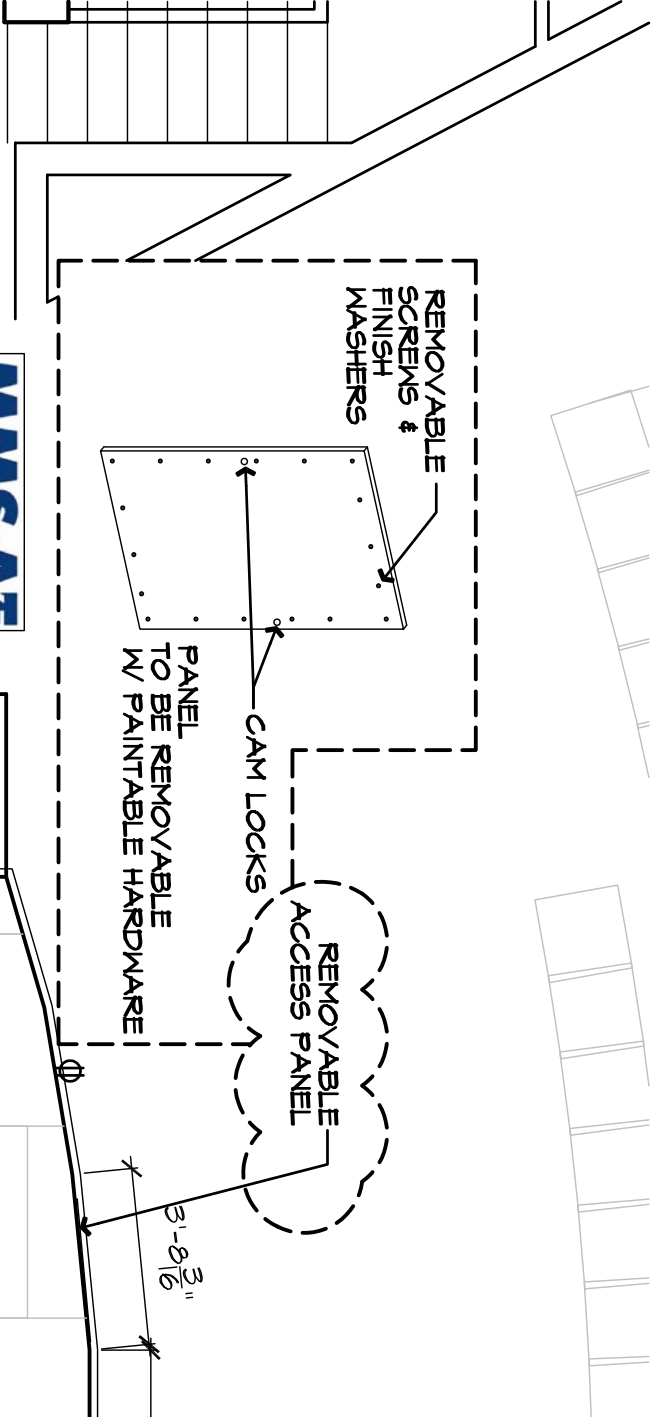

SD1

ACCESS PANEL CLARIFICATION
ISSUED 8.29.12

MMS-AE
600 WABASH AVENUE
TERRE HAUTE, IN 47907
812.234.5190

UP

MOUSE
HOLE

FLUSH PANEL 1'X1'
DOOR W/
5 KNUCKLE HINGES
AND A CAM LOCK
HARDWARE TO BE
PAINTABLE
QTY. OF ONE ON EITHER
SIDE OF STAGE

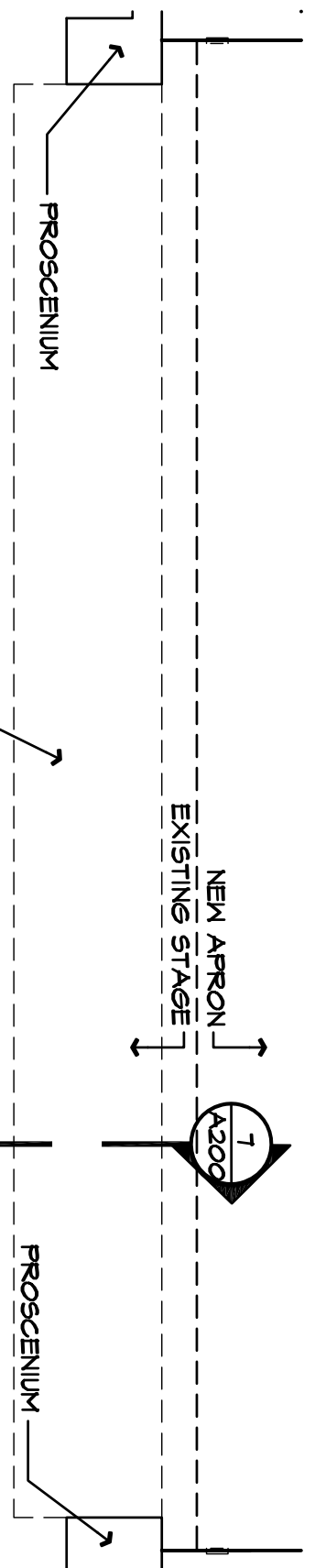

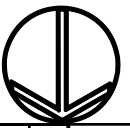
	SD2
	UNIT PRICE #1 CLARIFICATION ISSUED 8.29.12

MMS-AZE
 600 WABASH AVENUE
 TERRE HAUTE, IN 47807
 812.234.5190

UNIT PRICE #1:
 STRUCTURAL FRAMING PER LINEAR FOOT
 OF ASSEMBLY CONSISTING OF 2X12 STRINGERS
 @ 16" ON CTR. W/ 'SIMPSON' JOIST HANGERS
 AND JOIST BOARDS ON EITHER SIDE. IN EXISTING
 LIMELIGHT PIT TO SUPPORT NEW T&G AND MDF FLOOR.

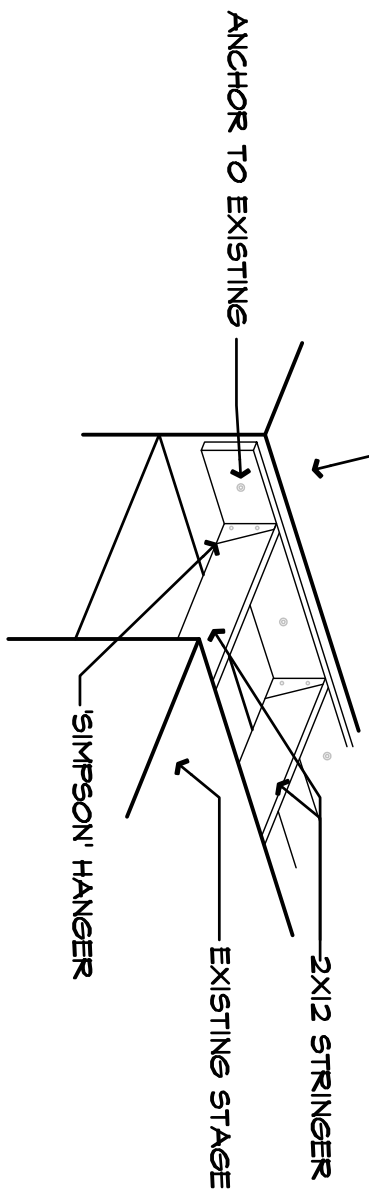

F1

002000
BID FORM

BASED ON BID FORM
FORM NO. 96
REVISED FORMAT 12/10/2003

GENERAL BID FOR PUBLIC BUILDING

PROJECT: DREISER THEATER STAGE RENOVATION

TO: INDIANA STATE UNIVERSITY
BOARD OF TRUSTEES
TERRE HAUTE, INDIANA

FROM:

(Name of Bidder) (Company Name)

(Address)

(City, State, Zip)

Phone Number _____

MBE/WBE BIDDING:

Is the Bidder (Prime Contractor) or any Subcontractor MBE or WBE Compliant? Yes No

See Section 00103 for requirements for MBE/WBE Compliance. Section 00104 must be **completed** by the **Apparent Low Bidder(s)** or any **MBE/WBE Bidder(s)** and submitted by 12:00 noon local time on the day following the Bid opening to the ISU Purchasing Department. Fax to (812)-237-3599

ADDENDA

The following Addenda have been received. The modifications to the bidding documents noted therein have been considered and all costs thereto are included in the Bid Sum(s).

Addendum # _____	Dated _____
Addendum # _____	Dated _____
Addendum # _____	Dated _____
Addendum # _____	Dated _____

OFFER:

Pursuant to and in compliance with 'Instructions to Bidders', and other Bidding Documents prepared by the Indiana State University Facilities Management Department for the above mentioned project, the undersigned, having become thoroughly familiar with the terms and conditions of the proposed Contract Documents and with local conditions affecting the performance and costs of the Work at the place where the Work is to be completed, and having fully inspected the site in all particulars, hereby proposes and agrees to fully perform the Work within the time stated and in strict accordance with the intent of the proposed Contract Documents, including furnishing bonds, insurance, labor, materials, and to do all the Work required to construct and complete in accordance with the proposed Contract Documents as follows:

002000
BID FORM

BASE BID

_____ Dollars (\$_____)
(State Amount in Words)

ALLOWANCES

1. \$ 40,000.00 shall be included in the Base Bid for Fly Rigging.
2. \$5,000.00 shall be included in the Base Bid for Unforeseen Conditions.

Indiana State University is a Tax Exempt Institution and Indiana Sales Tax for products permanently incorporated in work shall not be included as part of the Bid. All other applicable Federal, State and Local taxes shall be included in the Bid sum.

002000
BID FORM

ACCEPTANCE

This offer shall be opened to acceptance and is irrevocable for the periods as follows:

- Base Bid and All Alternates One Hundred Twenty (120) days from the Bid opening date.

If the Owner accepts the bid within the time period stated above, Bidder will:

- Execute the agreement within seven (7) days of receipt of the Contract.
- Furnish the required bonds and insurance certification within seven (7) days of receipt of Notice to Proceed
- Commence work with in seven (7) days of receipt of Notice to Proceed or as Directed by the Owner.

The undersigned Bidder agrees to coordinate and expedite his work and that if the Notice to Proceed is

given by _____, 201____ the work will be substantially complete by

_____, 201____.

It is understood that the Owner reserves the right to waive any irregularities in Bidding and to reject any or all Bids. It is further understood on Bids with multiple Bid Packages the Owner reserves the right to selectively Award individual Bid Packages to multiple Prime Bidders submitting the lowest and best Bids for the individual Bid Packages.

NON-COLLUSION AFFIDAVIT

The Bidder, by its officers and agents or representatives present at the time of filing this bid, being duly sworn, say on their oaths that neither they nor any of them have in any way, directly or indirectly, entered into any arrangement or agreement with any other bidder, or with any public office of the State of Indiana, of any county or municipality or other public offices whereby such affiance or either of them, has paid or is to pay to such other bidder or public officer any sum of money, or has given or is to give to such other bidders or public officer anything of value whatever, or such affiance of affiance or either of them has not, directly or indirectly entered into any arrangement or agreement with any other bidder or bidders, which tends to or does lessen or destroy free competition in letting of the contract sought for by the attached bids; that no inducement of any form or character other than which appears upon the face of the bid will be suggested, offered, paid, or delivered to any person whomsoever to influence the acceptance of the said bid or awarding of the contract, nor has this bidder any agreement or understanding of any kind whatsoever, with any person whomsoever to pay, deliver to, or share with any other person in any way or manner, any of the proceeds of the contract sought by this bid.

NON-DISCRIMINATION

The undersigned and its Subcontractors, if any, shall not discriminate against any employee or applicant for employment, to be employed in the performance of this Contract, with respect to their hire, tenure, terms, conditions or privileges of employment or any matter directly or indirectly related to employment because of their sex, race, natural origin, ancestry or religion or disability as prohibited under the Americans with Disabilities Act. Breach of this covenant may be regarded as a material breach of the Contract.

CERTIFICATION OF UNITED STATES STEEL PRODUCTS

The undersigned bidder certifies that the bidder and all Subcontractors will comply with the statutory obligations to use steel products made in the United States.

EXPERIENCE QUESTIONNAIRE

List similar projects completed by your organization:

1. Contract Amount _____
Description _____
Date Completed _____
Owner _____
(Name and phone #)

2. Contract Amount _____
Description _____
Date Completed _____
Owner _____
(Name and phone #)

List similar projects currently under construction by your organization

1. Contract Amount _____
Description _____
Date Completed _____
Owner _____
(Name and phone #)

2. Contract Amount _____
Description _____
Date Completed _____
Owner _____
(Name and phone #)

Yes No Has your organization ever failed to complete any work awarded it?

If yes, where and why?

002000
BID FORM

Yes No Does your Organization have any pending litigation or litigation completed within the past five (5) years initiated by your Organization or the Owner as a result of your work on another Project?

If yes, attach a complete listing, with your Bid, of all such litigation(s) and name(s) of Institutions and/or Parties involved with complete contact information. Failure to submit this information may result in disqualification of your Bid.

Yes No Has your Organization been cited for violation of State or Federal regulations within the past twelve months?

If yes, what was the violation and resolution?

List references from firms for which your organization has performed work. Provide firm name, contact person name and phone number.

BIDDERS FINANCIAL STATEMENT

With their Bid or before award of the Bid, the Bidder shall submit their most current financial statement and vendor trade credit references as evidence of financial capability to perform the work.

APPENDICES

The following Appendices are submitted with the Bid:
Appendix A - Material and Subcontractors List
Appendix B - Unit Prices

002000
BID FORM

OATH AND AFFIRMATION

Attested to this ____ day of _____, 201____

By _____

ACKNOWLEDGMENT

State of _____

SS:

County of _____

_____ being duly sworn, deposes and
(Name of person)

says that he/she is _____ of
(Title)

_____ and that the
(Name of organization)
statements contained in the foregoing bid, certification and affidavit are true and correct.

Subscribed and sworn to before me by _____

this ____ day of _____, 201____

Notary Public

My Commission Expires _____

County of Residence _____

002000
BID FORM

SUPPLEMENTS TO BID FORM

TO: INDIANA STATE UNIVERSITY
PROJECT: DREISER THEATER STAGE RENOVATION
DATE: _____

SUBMITTED BY:
(full name)

(full address)

In accordance with Instructions to Bidders and Bid Form, we include the Supplements to Bid Form for Appendices listed below. The information provided shall be considered an integral part of the Bid Form.

Appendix A - Subcontractor and Manufacturers List (to be submitted at time of Bid)
Failure to submit may be cause to disqualify bid

(Bidder)

(Project)

The following will be performed (or provided) by the Subcontractors and Manufacturers listed herein and coordinated by us.

The Prime Contractor (Bidder) shall use the Subcontractors, Suppliers, Materials and Equipment as listed in this Appendix "A" submitted at the time of Bid. There shall be no changes permitted to this list unless the Owner determines the Subcontractors, Suppliers, Materials or Equipment are not acceptable. The Owner shall notify the Prime Contractor (Bidder) in writing within two (2) working days after receipt of Bids of the unacceptable Subcontractor(s), Supplier(s), Material(s) or Equipment(s).

(Listings begin on next page)

002000
BID FORM

SUBCONTRACTOR LIST

Bidder shall provide the names of all applicable Subcontractors

Description	Subcontractor
General Construction	_____
Flooring Work	_____
Painting Work	_____
Electrical Work	_____
Fire Alarm	_____

(Supplier and Manufacturer List begins on next page)

002000
BID FORM

Appendix B – Unit Prices

1. Structural framing per linear foot consisting of (2) quantity 2 x 12 x 3, 16 inches on center with Simpson joint hangers and joist boards on either side

END OF SECTION 002000

012360
ALLOWANCES

PART 1 – GENERAL

1.01 RELATED DOCUMENTS

- A. Drawings and general provisions of the Contract, including General and Supplementary Conditions and other Division 01 Specification Sections, apply to this Section.

1.02 SUMMARY

- A. This Section includes administrative and procedural requirements governing allowances.
 - 1. Certain materials and equipment are specified in the Contract Documents by allowances. In some cases, these allowances include installation. Allowances have been established in lieu of additional requirements and to defer selection of actual materials and equipment to a later date when additional information is available for evaluation. If necessary, additional requirements will be issued by Change Order.
- B. Types of allowances include the following:
 - 1. Lump-sum allowances.
 - 2. Unit-cost allowances.
 - 3. Contingency allowances.
 - 4. Testing and inspecting allowances.
 - 5. Quantity allowances.
- C. Related Sections include the following:
 - 1. Division 1 Section "Contract Modification Procedures" for procedures for submitting and handling Change Orders.
 - 2. Division 1 Section "Quality Requirements" for procedures governing the use of allowances for testing and inspecting.

1.03 SELECTION AND PURCHASE

- A. At the earliest practical date after award of the Contract, advise the Architect of the date when final selection and purchase of each product or system described by an allowance must be completed to avoid delaying the Work.
- B. At Architect's request, obtain proposals for each allowance for use in making final selections. Include recommendations that are relevant to performing the Work.
- C. Purchase products and systems selected by Architect from the designated supplier.

1.04 SUBMITTALS

- A. Submit proposals for purchase of products or systems included in allowances, in the form specified for Change Orders.
- B. Submit invoices or delivery slips to show actual quantities of materials delivered to the site for use in fulfillment of each allowance.

1.05 CONTINGENCY ALLOWANCES

- A. Use the contingency allowance only as directed by Architect for Owner's purposes and only by Change Orders that indicate amounts to be charged to the allowance.
- B. Contractor's overhead, profit, and related costs for products and equipment ordered by Owner under the contingency allowance are included in the allowance and are not part of the Contract Sum. These costs include delivery, installation, taxes, insurance, equipment rental, and similar costs.
- C. Change Orders authorizing use of funds from the contingency allowance will include Contractor's related costs and reasonable overhead and profit margins.

012360
ALLOWANCES

- D. At Project closeout, credit unused amounts remaining in the contingency allowance to Owner by Change Order.

1.06 TESTING AND INSPECTING ALLOWANCES

- A. Testing and inspecting allowances include the cost of engaging testing agencies, actual tests and inspections, and reporting results.
- B. The allowance does not include incidental labor required to assist the testing agency or costs for retesting if previous tests and inspections result in failure.
- C. Costs of services not required by the Contract Documents are not included in the allowance.
- D. At Project closeout, credit unused amounts remaining in the testing and inspecting allowance to Owner by Change Order.

1.07 UNUSED MATERIALS

- A. Return unused materials purchased under an allowance to manufacturer or supplier for credit to Owner, after installation has been completed and accepted.
 - 1. If requested by Architect, prepare unused material for storage by Owner when it is not economically practical to return the material for credit. If directed by Architect, deliver unused material to Owner's storage space. Otherwise, disposal of unused material is Contractor's responsibility.

PART 2 – PRODUCTS (Not Used)

PART 3 – EXECUTION

3.01 EXAMINATION

- A. Examine products covered by an allowance promptly on delivery for damage or defects. Return damaged or defective products to manufacturer for replacement.

3.02 PREPARATION

- A. Coordinate materials and their installation for each allowance with related materials and installations to ensure that each allowance item is completely integrated and interfaced with related work.

3.03 SCHEDULE OF ALLOWANCES

- A. Allowance # 1: A \$ 40,000.00 allowance shall be included in the Base Bid for Fly Rigging.
Allowance # 2: A \$ 5,000.00 allowance shall be included in the Base Bid for Unforeseen Conditions.

END OF SECTION 012360